

CANDIDATE  
NAME

CENTRE  
NUMBER

--	--	--	--	--

CANDIDATE  
NUMBER

--	--	--	--

**MATHEMATICS**

**1112/02**

Paper 2

**October 2016**

**1 hour**

Candidates answer on the Question Paper.

Additional Materials:      Calculator  
   Geometrical instruments  
   Tracing paper (optional)

**READ THESE INSTRUCTIONS FIRST**

Write your Centre number, candidate number and name on all the work you hand in.

Write in dark blue or black pen.

You may use an HB pencil for any diagrams, graphs or rough working.

Do not use staples, paper clips, glue or correction fluid.

DO **NOT** WRITE IN ANY BARCODES.

Answer **all** questions.

Calculator allowed.

You should show all your working in the booklet.

The number of marks is given in brackets [ ] at the end of each question or part question.

The total number of marks for this paper is 50.

This document consists of **20** printed pages.



1 Write the missing numbers in these ratios.

(a)  $45 : 60 = \text{.....} : 4$  [1]

(b)  $14 : \text{.....} = 2 : 5$  [1]

2 The diagram shows a probability scale.

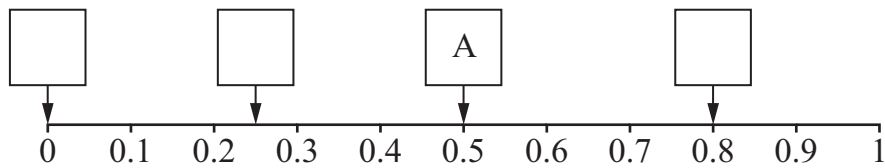

Write the letters for the probabilities of these events on the probability scale.  
The first one has been done for you.

A – The probability of a new baby being a boy.

B – The probability of picking a blue pen from a box containing 2 black pens and 8 blue pens.

C – The probability of rolling a 7 on a dice with faces numbered 1 to 6



D – The probability of picking the letter M at random from the letters in the word GAME.

[1]

3 The diagram shows 8 points labelled  $A$  to  $H$ .

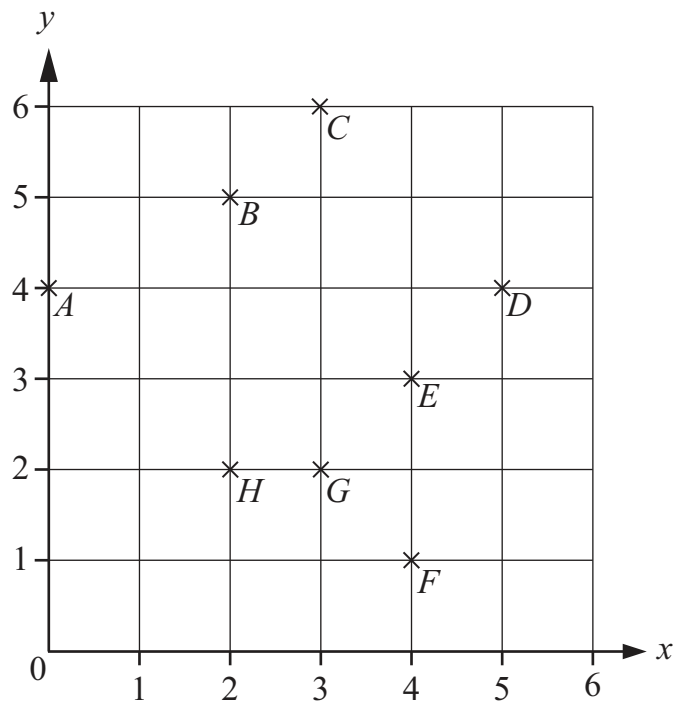

(a) Put a ring around the **two** points that the line  $y = 4$  passes through.

$A$      $B$      $C$      $D$      $E$      $F$      $G$      $H$

[1]

(b) Write down the equation of the line that passes through the points  $C$  and  $G$ .

.....

[1]

4 Here is a calculation.

$$109 \div 15 = 7 \text{ remainder } 4$$

Put a ring around the correct fraction for the answer to this calculation.

$$\frac{7}{4}$$

$$7 \frac{4}{109}$$

$$15 \frac{4}{7}$$

$$7 \frac{4}{15}$$

$$7 \frac{4}{7}$$

[1]

5 Translate the triangle one square right and three squares down.

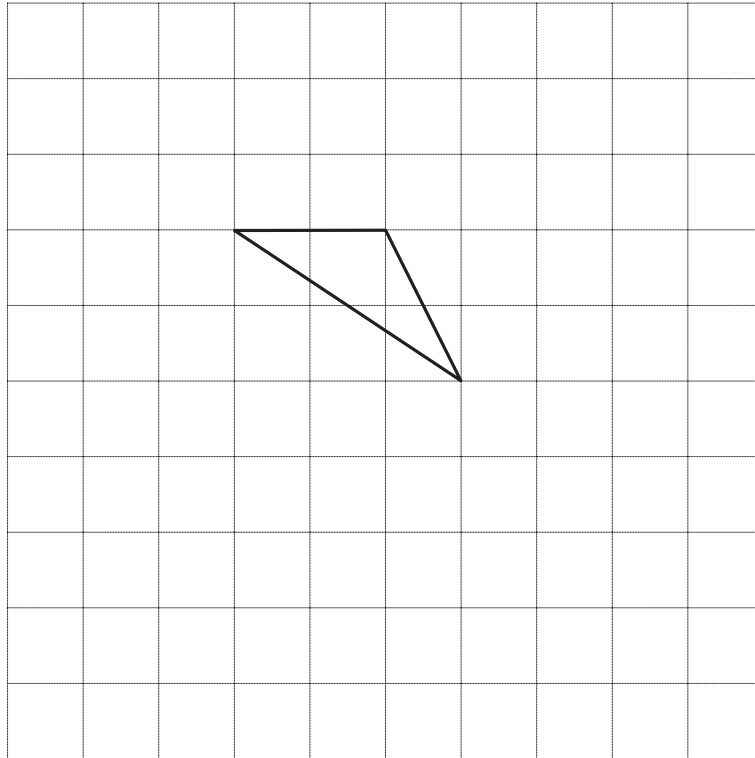

[1]

6 This graph shows some input and output values for a number machine.

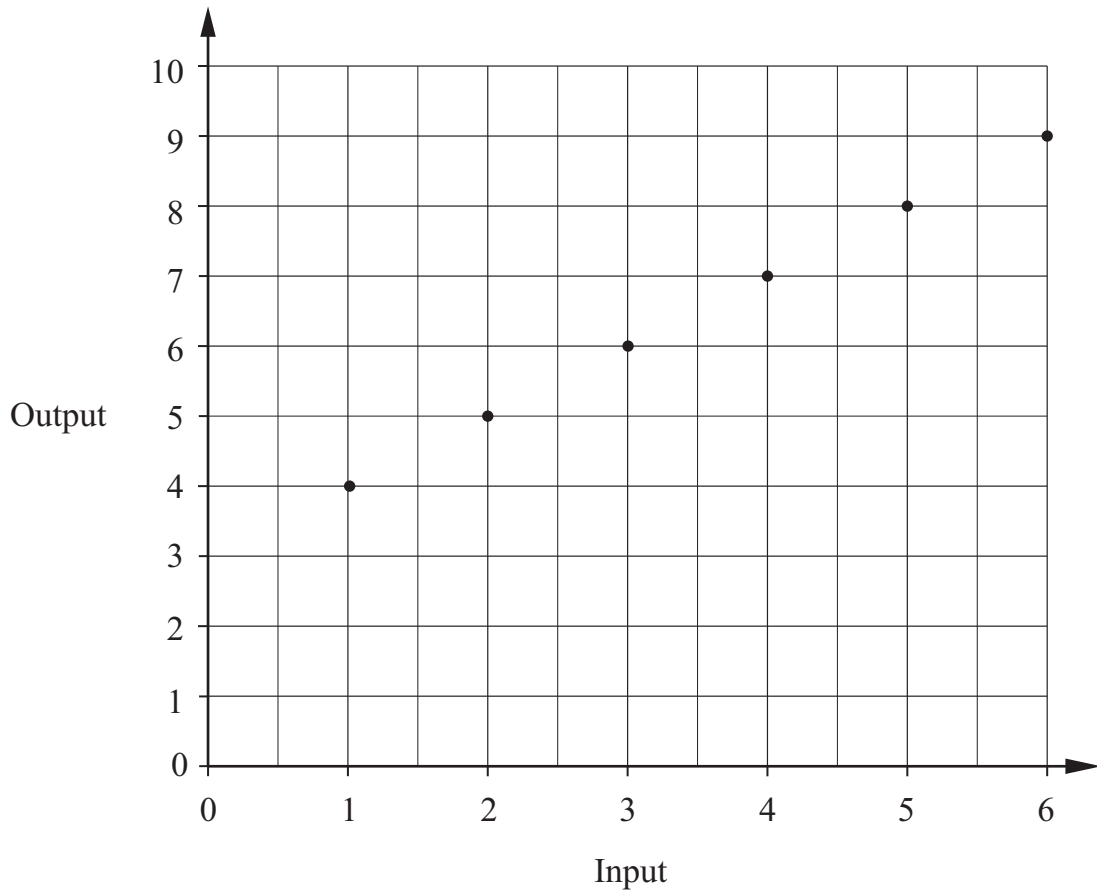

Complete the number machine.



[1]

- 7 Manjit wants to carry out a survey to find out what students in her school like to do in their spare time.  
She designs a questionnaire.

Here is one of the questions on her questionnaire.

What do you like to do in your spare time?  
Tick (✓) one box.

Read           Play sport

Write down one problem with this question.

.....  
..... [1]

- 8 Mia and Paul are looking at the same whole number.

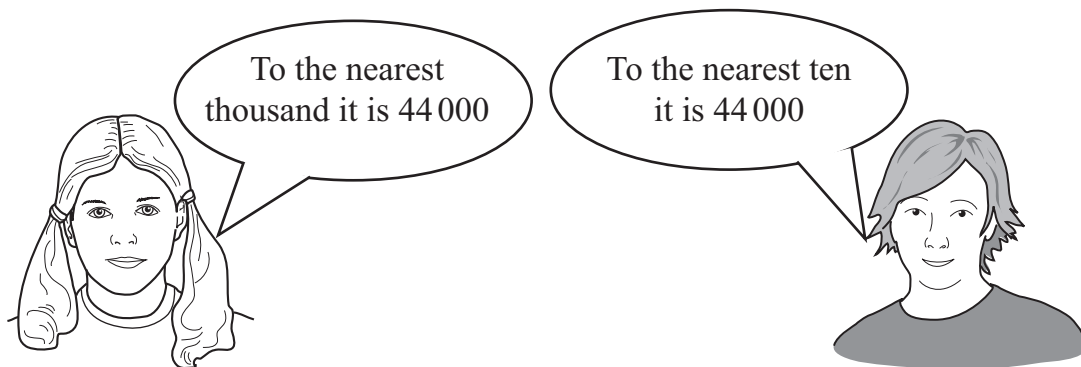





They are both correct.

Write down **one** possible value of the number.

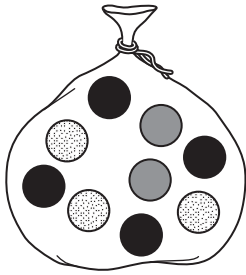
..... [1]

- 9 A bag contains black, grey and spotty beads.



Key	
	black
	grey
	spotty

A bead is picked at random from this bag without looking.

- (a) Write down the probability of **not** picking a black bead.

..... [1]

- (b) Write down the probability that the bead is black **or** spotty.

..... [1]

- 10 The population of a country is 39 634 274

Write this number correct to the nearest million.

..... [1]

11 The pie charts show the colours of men’s coats and women’s coats sold in a shop last Thursday.

**Men’s coats**

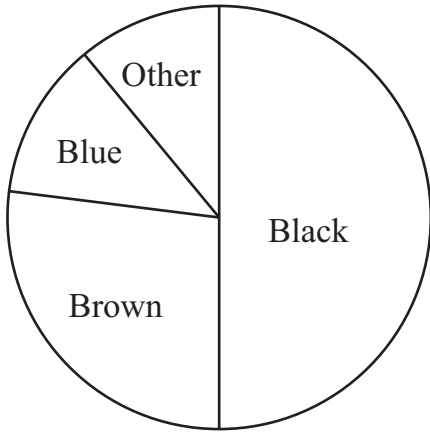

**Total: 76 coats sold**

**Women’s coats**

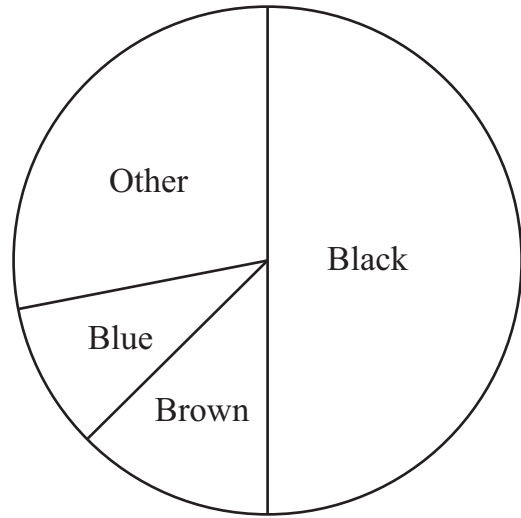

**Total: 108 coats sold**

Ahmed says,

Last Thursday the shop sold more women’s black coats than men’s black coats.

Tick (✓) to show if Ahmed is correct.

- Yes
- No
- Cannot tell

Give a reason to explain your answer.

.....  
 ..... [1]



- 12 The graph shows the number of hours of sunshine for six days in November.  
The column for 10-Nov is missing.

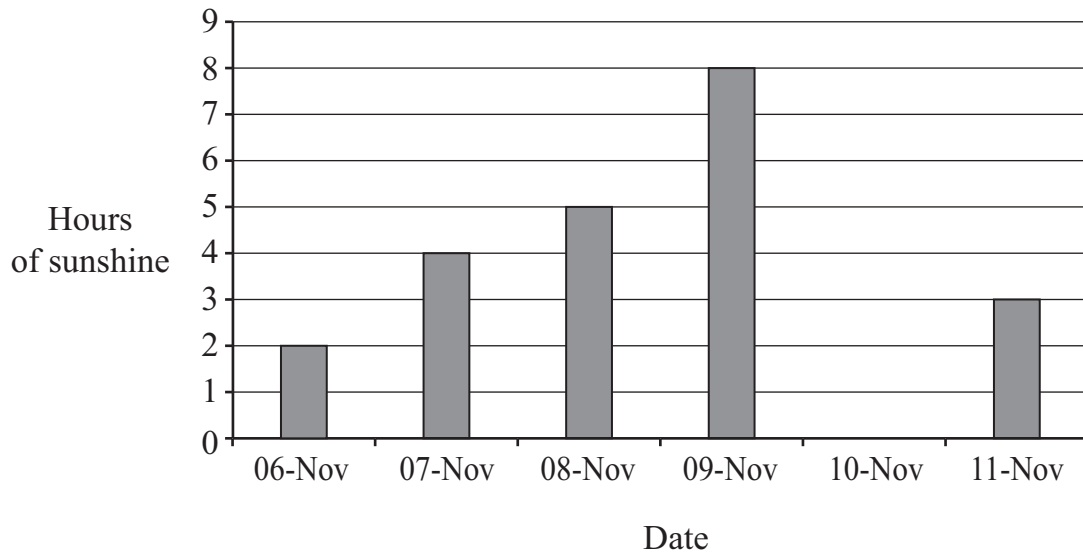

The mean number of hours of sunshine for the **six** days is 4.5

Calculate how many hours of sunshine there were on 10-Nov.

..... hours [2]

- 13 Mario, Franco and Gina share 153 badges in the ratio 2 : 3 : 4

Work out how many badges Mario gets.

..... badges [2]

14 Raj has a present to wrap.



He has a choice of 3 colours of wrapping paper: blue, red or green.  
 He has a choice of 2 colours of ribbon: yellow or green.

Raj chooses the wrapping paper and the ribbon at random.

(a) Complete the table to show all the possible colour combinations.  
 You may not need all the rows in the table.

Wrapping paper	Ribbon
Blue	Yellow
Blue	Green

[1]

(b) Write down the probability that the ribbon is the same colour as the wrapping paper.

..... [1]

## 15 Simplify

(a)  $t \times t \times t \times t$

..... [1]

(b)  $3r - r^2 + 5r + 3r^2$

..... [2]

16 Tick (✓) all the **correct** statements about the number 66 is a multiple of 12 6 is a factor of 18 6 is a prime factor of 30 6 is a common factor of 42 and 60 6 is the highest common factor of 24 and 36 

[2]

17 The diagram shows a triangular prism.

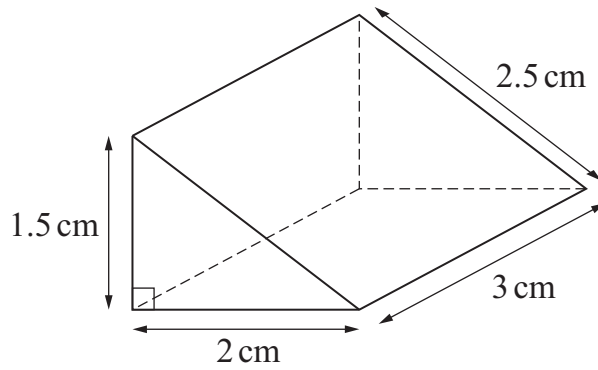

NOT TO SCALE

Draw accurately a net of this prism.

The base has been drawn for you.

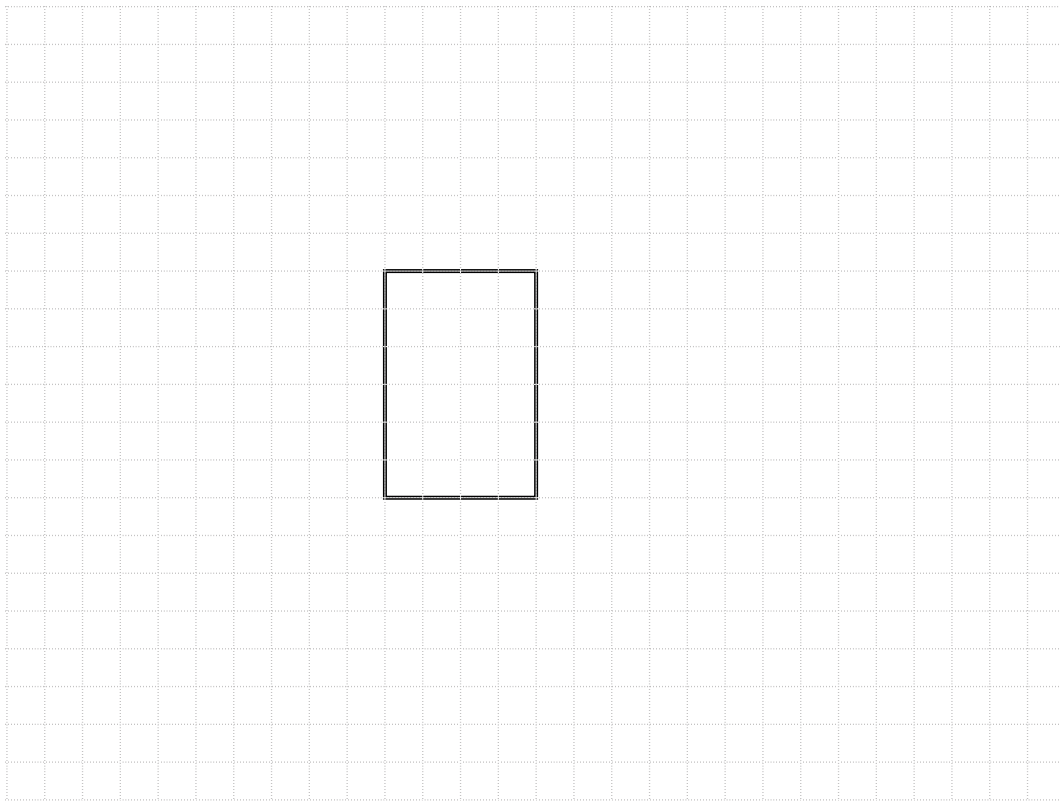

[2]

18 Sandra takes an 80-mile train journey from Wellington to Palmerston North.

Change this distance to kilometres.

..... kilometres [1]

19 Write as a single fraction.

(a)  $\frac{2}{x} + \frac{7}{x} - \frac{1}{x}$

..... [1]

(b)  $\frac{1}{2} + \frac{t}{m}$

..... [2]

20 Gemma can pay for a book in dollars (\$) or in euros (€).

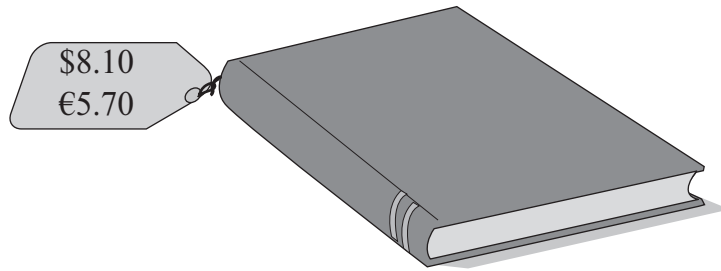

Gemma wants to pay the lowest amount for the book.  
The exchange rate is \$1 = €0.72

Work out which currency Gemma should use.

Dollars  Euros

You must show your working.

[2]

21 (a) Here is a relationship involving powers of 7

$$7^x \times 7^y = 7^8$$

$x$  and  $y$  are positive whole numbers each greater than 1

Write down **one** possible pair of values for  $x$  and  $y$ .

$x =$  .....

$y =$  ..... [1]

(b) Here is another relationship involving powers of 5

$$5^m \div 5^n = 5^4$$

$m$  and  $n$  are positive whole numbers each greater than 1

Write down **one** possible pair of values for  $m$  and  $n$ .

$m =$  .....

$n =$  ..... [1]

22 This table shows the mass of a child at different ages.

Age	Mass in kilograms
5	18.3
6	20.3
7	22.6
8	25.3

(a) From age 8 to age 9 the child's mass increases by 12%.

Calculate the mass at age 9

..... kg [1]

(b) Calculate the percentage increase in mass from age 5 to age 8

..... % [2]

- 23 40 children are in a running club.  
 They run a 400-metre race in April and again in July.  
 Their running times are shown in the frequency diagrams.

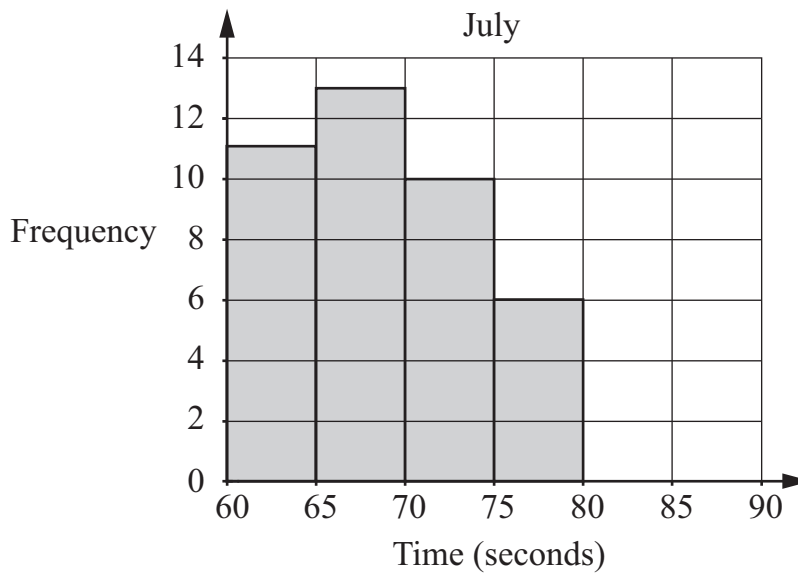
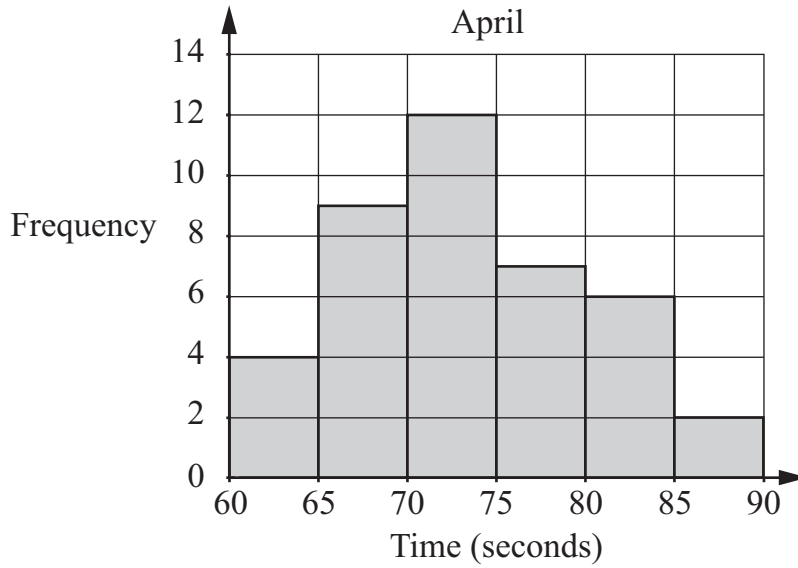

Put a ring around the month in which the children run the race more quickly.

April

July

Give a reason for your answer.

.....  
 ..... [1]



- 24 Bilal wishes to travel from Eastport to Gordonton.  
He can choose between two routes.

Route A: Direct route

Route B: Going through Timpton

The distances for each route are shown on the diagram.

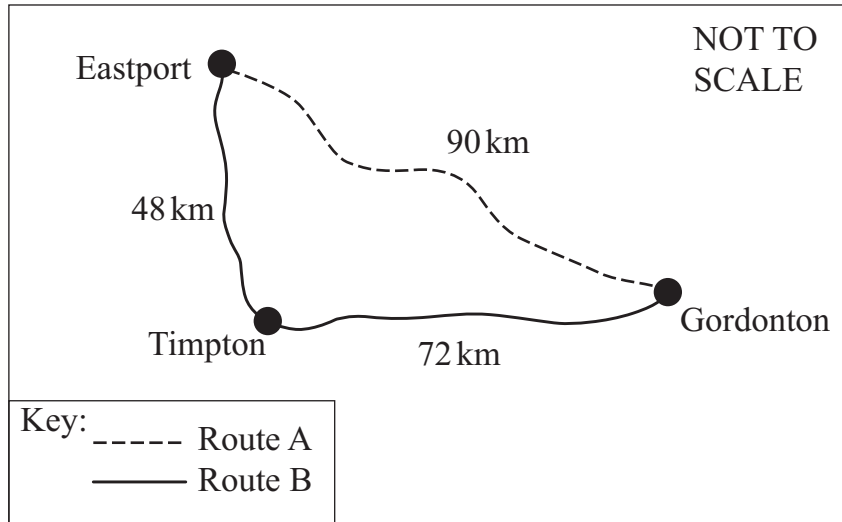

If he travels on Route A, he can travel at an average speed of 40 kilometres per hour.  
If he travels on Route B, he can travel at an average speed of 50 kilometres per hour.

Work out the difference, in **minutes**, between the journey times using the two routes.

.....minutes [3]

25 Find the first 4 terms of these sequences.

(a) The position-to-term rule is multiply by 2 then add 3

..... [1]

(b) The **third** term is 17, the term-to-term rule is add 5

..... [1]

26 A farmer wants to sow seed on a field with an area of 120 000 square metres.  
He needs 10 grams of seed per square metre of field.  
One kilogram of seed costs \$0.40

Work out the cost of the seed that the farmer needs.

\$ ..... [2]

27 The graph shows the cost of gold in dollars.

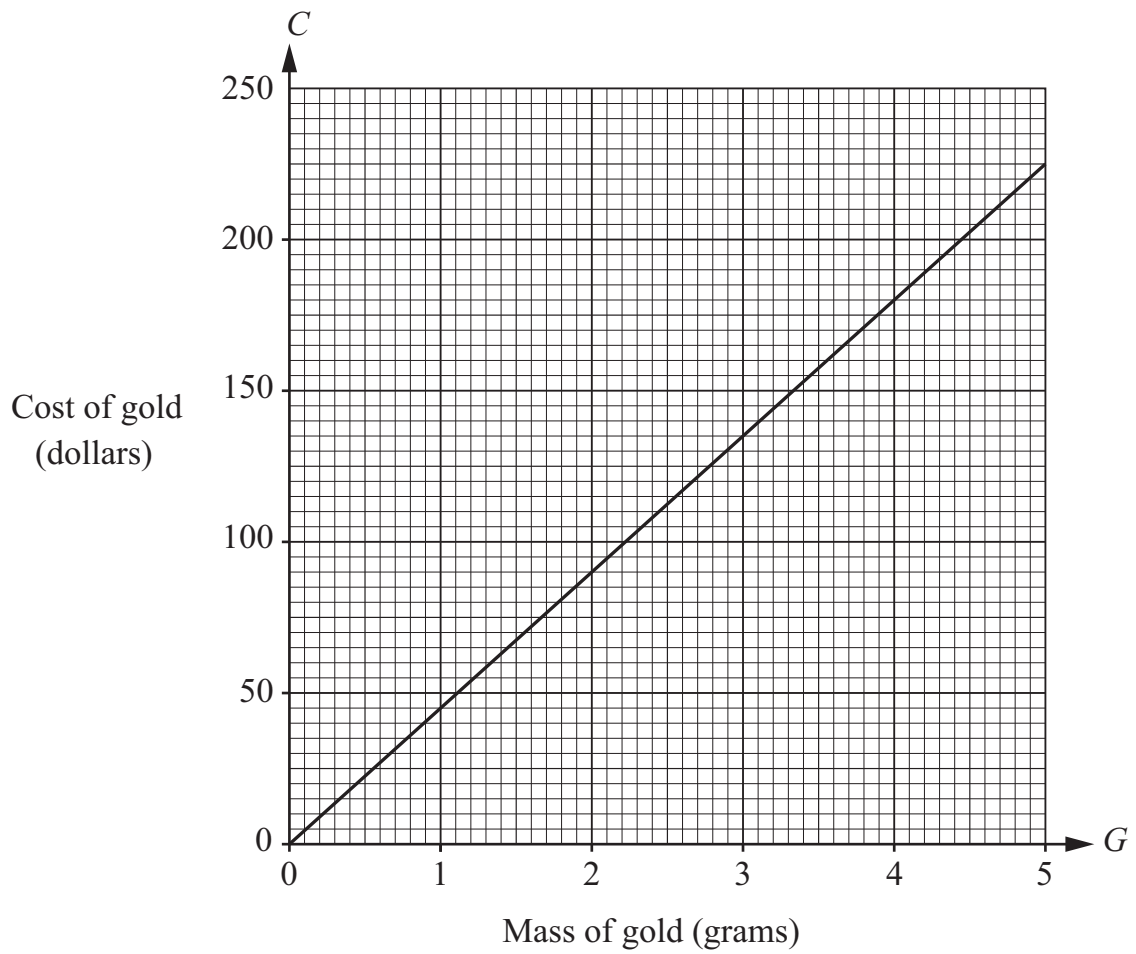

Use the graph to find a formula for the cost in dollars,  $C$ , of  $G$  grams of gold.

$$C = \dots\dots\dots [1]$$

28 Describe fully the single transformation that maps triangle  $A$  onto triangle  $B$ .

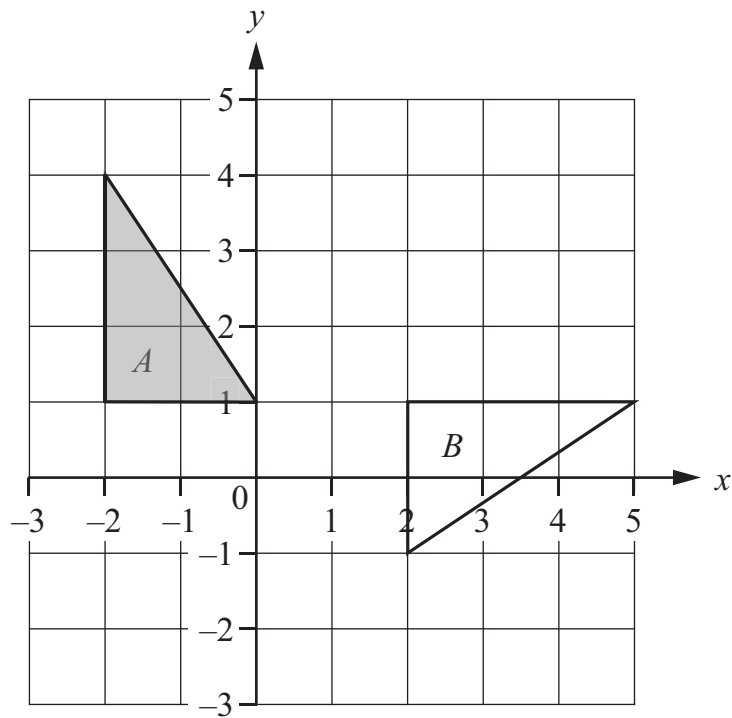

.....  
 ..... [3]

Permission to reproduce items where third-party owned material protected by copyright is included has been sought and cleared where possible. Every reasonable effort has been made by the publisher (UCLES) to trace copyright holders, but if any items requiring clearance have unwittingly been included, the publisher will be pleased to make amends at the earliest possible opportunity.

To avoid the issue of disclosure of answer-related information to candidates, all copyright acknowledgements are reproduced online in the Cambridge International Examinations Copyright Acknowledgements Booklet. This is produced for each series of examinations and is freely available to download at [www.cie.org.uk](http://www.cie.org.uk) after the live examination series.

Cambridge International Examinations is part of the Cambridge Assessment Group. Cambridge Assessment is the brand name of University of Cambridge Local Examinations Syndicate (UCLES), which is itself a department of the University of Cambridge.